

## Renewal and Expansion of An Old 6-M TVRO Into 7.8-M for EME = A DINOSAUR is (almost) Coming Back=

JH1KRC, Michiaki Watanabe (Mike)

Before the age of the internet through the optic fiber networks, there was a “Jurassic era” of parabolic antennas of large diameters for the satellite telecommunications around the world. The satellite television broadcasting also looks to be in fashion in the U.S. and some other foreign countries in 1980’s. To see the advertisement of the U. S. satellite TV systems of that era, the systems commonly used solid dishes. These satellites used C-band, for which the antenna size ranges 2-3 meters approximately. C-band parabolic dish with mesh reflectors of the equal size, for the same purpose, is called TVRO (television receiving only). This mesh reflector dish might be another choice of satellite watchers for economical reason. Also, it should be nice against wind load.

The size of C-band solid dish, and TVRO also, are large enough and convenient for amateurs to modify for UHF and microwave activities, and to start 23 cm and up EME operation. This may not be an amateur’s bricolage, but **a great recycle of a dish of professional design.**

While in Japan at that time, the world satellite TV watching was not common, because there had been no C-band, nor Ku-band domestic TV broadcasting satellites. Therefore C-band dish might be rare to see here around in Japan. Actually only a few enthusiastic amateurs, and foreigners living in Japan, might love to use large-size TVRO dishes of 2 or 3-meters, or larger in rare cases, to receive oversea TV broadcasting from geostatic satellites over the Pacific, or the Indian ocean. These broadcasting were not scrambled, but mostly through the long-distance paths at low take-off angles.

JA amateurs, if fortunate enough, can find surplus large TVRO reflectors, which are abandoned after cable TV and Ku-band satellite TV broadcasting became popular here, and satellite broadcasting had become scrambled, or digitalized already. Such large reflectors are no more in use for the original purpose. **These dishes look as if they were fossils of dinosaurs of Jurassic era** which already disappeared from the real world. But why not excavate the fossils? Around you there must be some foot-prints, or traces of their active lives as **the most evolved creatures of that era.**



Montana Dinosaur Center <https://tmdinosaurcenter.org/>

### An Old Tale of My Two TVRO's

Mr. K. is the former owner of my old 4.4-m TVRO, lived in Yaizu, Shizuoka (JA2). In 1980's he purchased a brand-new **PARACLIPSE 14-1/2' TVRO dish**, an import from USA, and self-built it with much effort and enjoyed watching oversea TV programs. Several years later he decided to purchase **ORBITRON T-20 TVRO**, a larger 6-m dish, also an import from USA, to see the oversea TV programs with more clear vision from the satellites above Indian Ocean.

Incidentally in 1996, I saw Ham-Ads in a radio magazine of his sales of the old 4.4-m TVRO, and I purchased it from him. June 2003, after the station inspection by telecom officials, I got **EME license** and began EME operation on 70/23 cm from the present QTH. By the time, I had F1EHN moon tracking program in my computer, but **the first rotation systems were pulse-count, manual switching motor-controlled, nearly (but not exactly) in equatorial rotation**, and I could not apply the F1EHN into this system. Instead, **an NTSC video camera** was installed behind the reflector, so that if WX was fine and clear in the night you can see the moon in the video monitor. It was easy, and exciting moon tracking at night. But **the probability of clear moon vision might be of 30 %** or less here. Even in the rain you can see the moon in a short moment. Then it was a chance to begin tracking the moon.



SM0PYP(WA6PY) 5-polarizer feedhorn



4.4-m TVRO with video camera

Fortunately, my CW echo on 23 cm used to be strong enough to hear audibly. So, I could **track the moon by occasional monitoring of my own echo**, even in the day or night. But eventually it

sometimes took an hour until I hit the moon properly. **The moon paths are almost linear and parallel** in the azimuth/elevation scales on a sheet of graphic paper. You can track the moon orbit on a linear line of that date by the pulse digits of EL/AZ controllers (satellite trackers) show you. In such a tough and tiring tracking situation, I worked 75 initials in CW on 23 cm, and some 10's on 70 cm. It took almost 10 years, because my operation was limited only several days in a year.

By the time I became active in EME mostly on the contest weekends, Mr. K. decided to stop satellite TV watching with his 6-m TVRO. He had contracted a cable TV, so that he could enjoy watching foreign TV programs without maintaining his “dragon” in the back yard.



Mr. K. asked me **to purchase his 6-m TVRO** again. I signed OK, very immediately, and took all the parts of this large TVRO reflector, bulky pedestal tower of 3-m high, and a couple of 50-m control cables, on a 10-ton crane truck. Mr. K. was a man of honesty, and he had written and sketched all the procedures of his antenna construction, and destruction also, into detail in 7 note books. Hundreds of pictures with writing comments by Mr. K. later helped me so much. All these materials, without single piece left, were carried 400 km, and unloaded at a corner of the property where my shack is located, and several boxes and mesh sheets were kept at my parent house.

Unfortunately, this “old dragon” was forgotten for many years. Because I had to drive my car 240 km from Chiba only on weekends to come to my shack in Nasushiobara, Tochigi, and most of my time there was spent on EME, or HF operating.

My **15-m EME echo** was heard and recorded in early 2006. This was **the world-first report**, and it allowed me for a presentation to perform at 2006 International EME Conference in Wuerzburg.

Other activities like **two BIG-DISH operation of 8N1EME (2006-2007) and 8J1AXA (2008-2010)** took so much hours and days, both of which were exciting events. Instead, everything in my shack got deteriorated in years without good maintenance.



8N1EME at KDDI Ibaraki



8J1AXA at JAXA Katsuura



JH1KRC dish covered by Nature

In 2012, my 4.4-m TVRO antenna system had a chance to be modified into **AZ/EL rotation with OE5JFL/HB9DRI controller** on a new auto-motorized pedestal tower. Feed horn was replaced from SM0PYP/WA6PY 5-polarizer feed (which worked excellently) to **OM6AA round septum feed with super choke ring** by chance. This new system works fine and provided me really comfortable EME operation. The next year my friend Takuro JE1OYE and I won the world-first place in 2013 ARRL EME Contest muti-op. single band 23 cm CW.



OE5JFL/HB9DRI controller



EL MAB25 encoder rotation stabilizer



OM6AA septum feed

In 2015, I had another chance to get my profession within only 5 km from my shack. This allowed me to maintain my shack of 20 years old, including HF systems, almost every day and night. Tri-Ex Skyneedle 36-m tower (delivered from W6KPC, Frank) installed with 15-m and 20-m 6-element monoband yagis had to be repaired also. This antenna provided me of my 15-m EME echo in 2006, but I have heard no more echo on 15-m ever since.

As maintenance of my shack developed, I began thinking about some improvements in EME system. I needed the eastern moon path of the low elevation angle. The reason was that I have not worked **South America** for my 23 cm WAC. Another reason was, in 20 years, trees surrounding my antenna and shack have grown up and it became more difficult specially in the west moon path in low take-off angles. So that I have to stop operation almost one hour before the moon set at the

northwestern mountains.

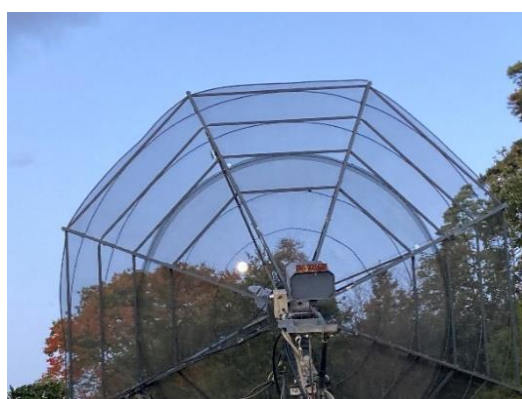

Western window of 23 October, 2023 (ARRL EME Contest). Photos of the same period.

### Visits to Large Diameter Antennas for EME

Since I began EME operation in 2003, I found several stations have very strong echo and have very good receiving capability as well. They are highly admirable to me, and I had chance to visit some of them. In 2006, before I presented my own EME echo on 15-m band at the EME Conference in Wuerzburg, I visited HB9BBD 10-m, HB9Q 15-m, OE0ERC 8-m and OK1DFC 10-m. Later K5SO 8.5-m, and K5JL 6-m, W5LUA multi-band solid dish before the 2010 Dallas/Fort Worth Conference. I did not visit but VK3UM and F5SE also operated from extraordinary antennas.

In Japan, the legend tells of the 13-m dish of JA6DR who was active since 1976. And I visited JR4AEP 8.5-m (formerly 10-m), JA4BLC 6-m, JA4HZN 5-m, JA6AHB 6-m, JA6CZD 5-m, JA6XED 6-m, JA8ERE 4.5-m SOLID, JA8IAD 4-m, etc. My extraordinary experiences were to modify KDDI's 32-m Cassegrain (2006-2007) for 2 m/70 cm/23 cm/6 cm, and JAXA 18-m punched out metal dish (2008-2010) for 2 m/70 cm/23 cm, which are the historical EME operation in Japan.



HB9BBD 10-m



HB9Q 15-m (photo from HP)



OE0ERC 8-m



OK1DFC 10-m.



K5SO 8.5-m with 70 cm VE4MA



K5JL 6-m

All these antennas are fascinating, well designed and built with full of their ideas and efforts. I asked many questions, looked into details, and took hundreds of photos of course.

**During the COVID-19 pandemic** (April 2020-May 2023 in Japan), it gave me a chance not to go far even on weekends, and I decided to build **another EME antenna in a different location** in my property (you can see it in the photo above), so that the new antenna can see the low take-off angles (maybe well below 5 degrees) both in the direction of moon rise and moon set.

This idea reminded me that I have an old 6-m TVRO. Naturally, my HF/6 m antennas and towers were also planned to repair and renew, so that I could take part in DX contest again, and possibly experience the second HF EME.

The most southern corner of my property was selected to build up my second EME antenna, where I can see both the moon rise and moon set. Trees were cut down (I applied to the city office for it) and my **ANTENNA PLAZA** was opened.

Fortunately, or unfortunately, before this place began to work, one day I could work **PY2BS at the take-off angle of 5 degrees**, and completed my WAC on 23 cm CW. Soon after our QSO, PY2BS gave me his QSL directly. But because of COVID-19 restriction, my QSL was not sent out soon from the central post to Brazil. Anyhow, I could get **Worked All Continents (WAC) on 23 cm CW**.

## Fossils Were Excavated

Early 2020, **COVID-19 pandemic** slowly came to my area, and my excavation of fossils began. Most of the main parts of “new” 6-m TVRO were laid down under a blue sheet in my radio estate. Years had passed, and most of them got buried beneath the soil, grasses, and creepers. A blue sheet covering over the antenna materials was useful to remove the accumulated on the surface, even if it was already deteriorated and easy to tear up. Two brown snakes were found just during their intercourse. The main parts of my old “dinosaur” were kept in a corner of the property where my radio station is located, or just next to my shack, so that they were not missing, nor stolen.

The original paint was baking-finished. It looked rather strong and durable, and also not easy to remove for clean-up. The former owner Mr. K. lived in Shizuoka, close to the Pacific Ocean, and salt water possibly had come into every part of the steel materials under the paint, to cause deep and wide corrosion to develop later here in my QTH.



Spool (Hub), center of 16 trusses

Hub ring settles 16 trusses

## Dimension Measurement and Extension Design

This antenna originally had no graphic instruction, as Mr. K. said, and the only manuals contain parts list, and construction guidance without figure. Before remaking this bulky dragon, I decided to measure the dimensions of the reflector and the trusses. The parabolic curve, and truss structure were very important for me to design the feed-horn stay arms and extended part of the reflector.

First the dish diameter and height were measured with its 4-m sections, and then, when the 6-m sections were installed. Which part of the reflector has its “6 meters (20 feet)” diameter?

The end-to-end diameter of the two trusses was measured to be **6.30 meters**. And the height was **0.894 meters**. These figures will give you the information of the parabolic curve and focal point.



Focal point would be calculated by rectangular coordinates, or cylindrical coordinates.

$$x^2=4fy$$

This easy formula shows focus. If the dish radius (d) becomes 2f,  $\theta$  will be 90 degrees.

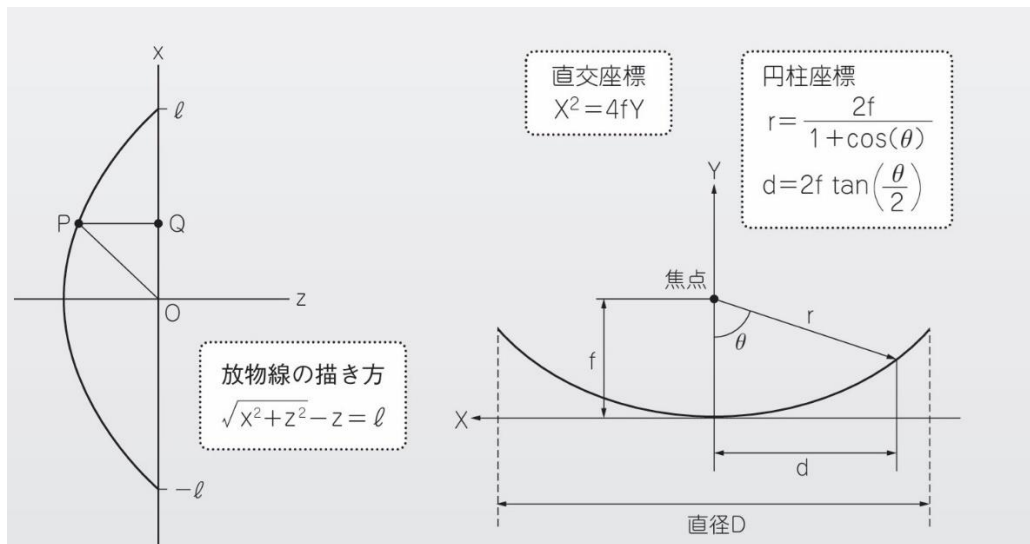

$$x^2=4fy, \quad f=2.775 \text{ (m)} \quad \text{(Figure: CQ ham radio , May 2024)}$$

**Note:** The different diameter of the bolts which you fix the trusses with, would influence the accuracy of the measurement, and the final preciseness of the dish reflector. So, before this action, I had to ask an owner of my local factory to give me some bolts and nuts of inch-sizes.

This **measurement procedure was occasionally repeated** after the 4-m sections, 6-m sections, and 7.8 m sections were built up. This measurement revealed the **dish diameter** in the specification brief seems to be **measured at the center of the mesh, between the tops of two trusses** side by side.



Later I found specifications of this antenna in web **catalog** showing the different focal length! (But within 2 %, I don't know why.) In actual operation, real focal point should be adjusted by moving the feed horn, on 23-cm band, several centimeters, back and forth. The **phase center** of your feed horn has its own focal point, possibly a few centimeters inside the aperture.

### **SPECIFICATIONS:**

<b>T20</b>			<b>T24</b>		
<b>Diameter:</b>	20.0'	(6.1m)	<b>Diameter:</b>	24.0'	(7.3m)
<b>Focal Length:</b>	108"	(274.3cm)	<b>Focal Length:</b>	108"	(274.3cm)
<b>F/D Ratio:</b>	.45		<b>F/D Ratio:</b>	.375	
<b>Gain at 4.2 GHZ:</b>	46.9 dBI		<b>Gain at 4.2 GHZ:</b>	47.9 dBI	
<b>Gain at 12.2 GHZ:</b>	53.5 dBI		<b>Gain at 12.2 GHZ:</b>	53.8 dBI	
<b>Shipping Weight:</b>	3150 lbs.	(1429 kg)	<b>Shipping Weight:</b>	3300 lbs.	(1497 kg)
<b>Crate Size: A:</b>	93"x50"x41"	(237x127x105cm)	<b>Crate Size: A:</b>	93"x50"x41"	(237x127x105cm)
<b>B:</b>	93"x34"x34"	(237x87x87cm)	<b>B:</b>	93"x34"x34"	(237x87x87cm)

### **My Antenna Specifications**

I tried to calculate specifications of the "excavated" 6-m dish and the modified 7.8-m. Each data of the diameter shows **the median length of the mesh to mesh**, not truss end to truss end. So, the diameter of this modified TVRO, 7.8 meters measured at the end-to-end of the trusses, may be calculated by the same way, **D=7.65 meters**.

Frequency = 1296 MHz,  $\lambda = 0.23$  (meters)

D: diameter (median mesh diameter)

G: gain, F: focus (2.775 meters)

HBW: half-power beam width

$$G = 6(D/\lambda)^2 \quad \text{HBW} = 60(\lambda/D)$$

$$\text{Effective aperture} = 0.6(\pi D^2/4)$$

1) D: 6 meters

$$G = 36.1 \text{ dBi} \quad \text{HBW} = 2.3 \text{ degrees}$$

$$\text{Aperture} = 16.96 \text{ m}^2 \quad \text{F/D} = 0.46$$

2) D: 7.65 meters (median mesh diameter)

$$G = 38.2 \text{ dBi} \quad \text{HBW} = 1.81 \text{ degrees}$$

$$\text{Aperture} = 27.6 \text{ m}^2 \quad \text{F/D} = 0.36$$

These figures above look very fascinating, and acceptable to me. So, why not continue to the modification to expand it?

If you like to calculate the dish characteristics of your antenna, for windows, visit this site:

- Parabola Calculator version 2.0

<https://mscir.tripod.com/parabola/>

### Cleansing of the Materials

Since most of the reflector parts, such as trusses, mesh rings, mesh strap to fix the mesh sheets onto the trusses, are made of aluminum, so the surface was badly corroded, dirty and rough. All of the aluminum materials were cleaned by high pressure water from a hydraulic pump, and then filed.

Inside of many of the one-inch square trusses were filled with soil, straws and rotten leaves for insects to live in. Before anything, to remove these wastes out from the pipes, I recommend you to tap or strike the trusses vertically on a concrete base. Such wastes would absorb water, and freeze.



### Trace and Calculation Results Matched

Cleaned trusses were carried into a conference room of my workplace. Large **graphic paper, printed with 50 mm x 50 mm square grids**, was very useful for **tracing the outlines of the truss structure**. Calculation results were plotted on the graphic paper, and I confirmed **the real dimension and the calculation matched exactly**. **X-Y plotting is useful** to determine further antenna construction, such as feed support, mesh ring structure, and truss extension, etc.

The reflector curve of this dish can be expressed in X-Y plots. “a” becomes very small number.

$$Y=aX^2, \quad a: 9.01 \times 10^{-5}$$

Some of the trusses were found swelling and badly **cracked** (maybe caused by icing inside), so that later these trusses needed repair work by press and welding at a local factory specialized for aluminum materials. By the way, welded parts have **slight gaps** to release water.



Calculated curve and trace would match well.

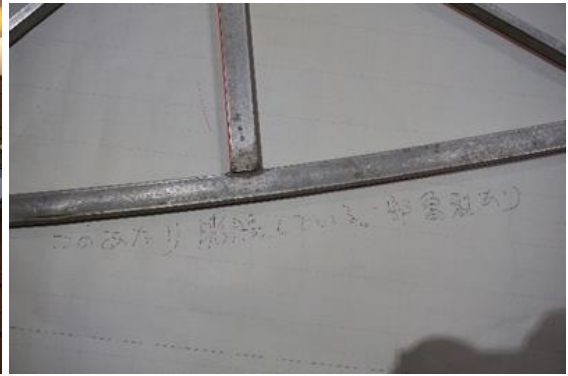

Crack and swelling 😞

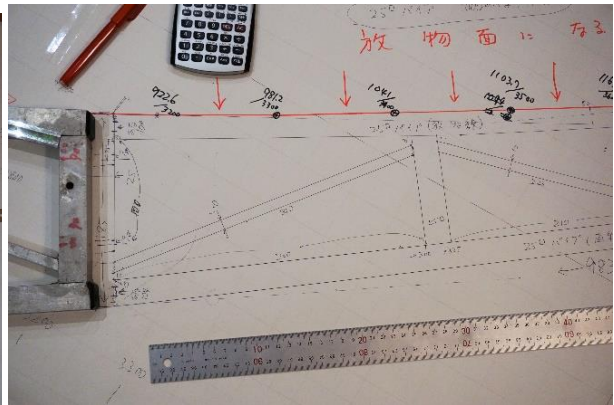

Along with 6-m section, the extended 7.8-m section was designed using 1 meter material.

After the **trace of original 6-m TVRO** finished, the **extension truss of 1 meter long** was designed (photo: above right) and ordered to a local factory.

Original material is 25.4 mm (1 inch) square, and the extended sections were made with 1000 mm long x 25 mm square aluminum tubes.

Since the final design including the mesh rings was not drawn yet, **drill holes had to be opened later. It was a big mistake of mine.** To drill the perpendicular holes, an applicator was designed and made from a solid steel bar. The idea may be OK, but it did not help well, or almost no use! Simple and precise hand drilling was better to me.

Another problem was **the position of connecting bolts between the two trusses.** If it is too close to the braces, **a bolt cannot be inserted into the hole** (the left hole in the photo below). So, careful designing/drawing should be done, otherwise you have to drill some more holes, as I had to do.



### Mesh Strips and Thread Drilling Screws

To settle the mesh sheets, **mesh strips** 3x1000 or 2000 mm were used. The overlap of mesh sheets, sandwiched between a mesh strip and truss surface, are drilled onto the front surface of each truss.

Since this is a second-handed antenna, some hole positions of the older sections were not exactly the same as others. (left photo) It seemed very difficult to determine which mesh strip would match to a certain truss. The extended section and strip were precisely drilled before installed. (right)



If 3 mm drill holes were made previously, 1/4" (6.35 mm) thread drilling screws would easily be tapped when the reflector mesh were settled down by the mesh strips. For the extended section all of this procedure had to be done on the higher part of antenna reflector, so I prepared this.

The thread drilling screw does not necessarily need this preparation hole. If you would take time the drilling screw itself will do this, but you have to do it on the reflector surface for some time.



Extension trusses were drilled, and painted in silver anti-corrosion paint. The fundamental base was made 3x3x3-meters with framed structure of the bolts. Two copper plates 1x1-meter square were buried for the earth grounding. In this area, about 2 meters beneath the soil ground it would be cobble layer.

### Mesh Rings Designed

**Three types mesh rings** for the extended section were designed and calculated. Since I don't use CAD, every calculation was done with hand drawings and my old **CASIO** multi-function calculator which I bought at Akihabara many decades ago. Still, this solar-powered calculator works well, but calculation was very difficult for me. My brain did not work better than the calculator, and the results of dimensions often changed.

**Mesh ring** is composed of a strait **L-angle 25x25x3 mm for enforcement**, and **a round arc and the end plates on the both sides** are made of **flat bars of 25x3 mm**. Each arc curve is the same as a part of dish circumference at the same height. Every set of mesh rings has its different dimensions, because of each radius and the different structure of the truss at the height.

So, I needed to draw three different mesh rings for the expanded reflector. Casio and hand drawings worked again, any way.

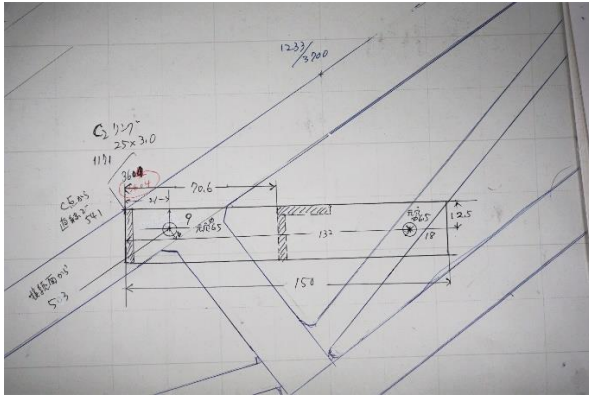

The second ring of the expanded section.



For the extended section, there are 3 types of mesh rings. Picture shows two of them. The longest one had to correct the dimensions, by my minor mistake, and went back to the factory.

**Arc curve** is the same as a part of dish circumference at the same height **L-angle strait bar** behind the ring for enforcement, and **flat bars at the end** of each ring to bolt, and also to enforce the truss connection. These end bars are placed horizontally (when the dish faces to zenith). Two 1/4" bolts were used each side for all of the mesh ring connection to trusses. These bolts should not collide or cross to the other bolts inside the truss pillars.

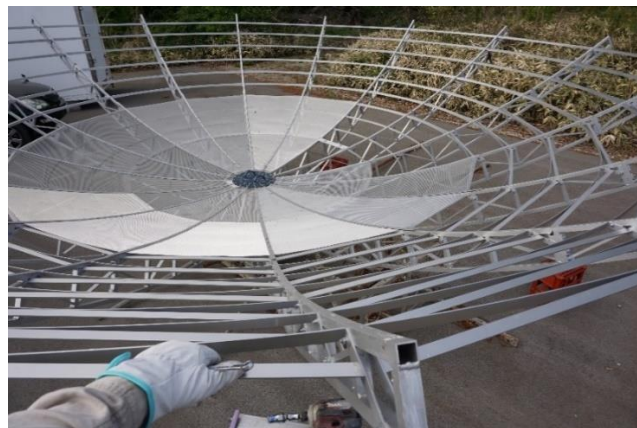

The last mesh ring was attached smoothly, 29 April, 2023.

### Seeking for Missing parts

Reflector mesh sheets and rusted steel bolts and nuts, orderly kept in a storage of my parent house, had already been discarded by my sister who did not know how precious they were. Every part was made in old standards of Wit “inch size”, which are very difficult to locate or purchase in Japanese market. Specially, hot-zinc-dipped materials of small sizes were very difficult to find.

5/16” (7.9 mm) was replaced by 8.0 mm. The difficult-to-find things missing were 1/4” (6.35 mm) bolts/nuts/springs and hex-head self-drilling screws. We have these of 6 mm size, but they do not build up this US-made dish precisely.

I was lucky enough to find a pro shop who is specialized in bolts & nuts, and deals with these small size zinc-dipped materials on their web pages. It took so much time to locate and order these things of various sizes I need. Most of those parts were purchased from this store in Gunma Prefecture. They sell these zinc-dipped products by 100 pcs., or so. But the prices were very reasonable.

Spring washer of 1/4” was not found. My friend Takuro JE1OYE kindly made a punching tool so that a 6 mm spring washer was punched and expanded into 6.35 mm (1/4”) very efficiently. It took 5 seconds each, and I made about 350 pcs. Isn’t it better than nothing?



Spring washer punching expander



Spring washers became 1/4”



New material thread screws

The last one very difficult to find, but available in the web markets was hex-head **self-drilling thread screw** of 1/4". I found one in a US store. It was not zinc-dip, but they say its surface is several times more durable than hot zinc-dipped. Since they do not sell it to outside USA, I asked Mike KL6M to buy 450 pcs. and send it to me. So nice! It was made in Taiwan.

### Mesh clips

Aluminum mesh sheets are clipped onto the mesh rings in a simple way. **Cut 1 mm stainless steel wire of 75 mm long** by a substantial scissors. **You need 3 seconds for one piece** to cut using a bulky scissors of a Chinese product. Bend 15 mm at one end of the clip wire. Put on from the front surface of the mesh sheet. Then hold at the lower end, and bend some 25 mm at the edge of mesh ring in immediate movement by substantial grasper. Then tighten the lower bent onto the mesh ring. **Hold up the end of clip wire** so that it would not prick your head. That's all. **See the video** in my slide show. Clips are reusable later.

This is the simplest and very effective method to settle down the aluminum mesh sheets onto the mesh rings. Twisting the clip wire takes time, and usually loose, so finally it does not satisfy you.

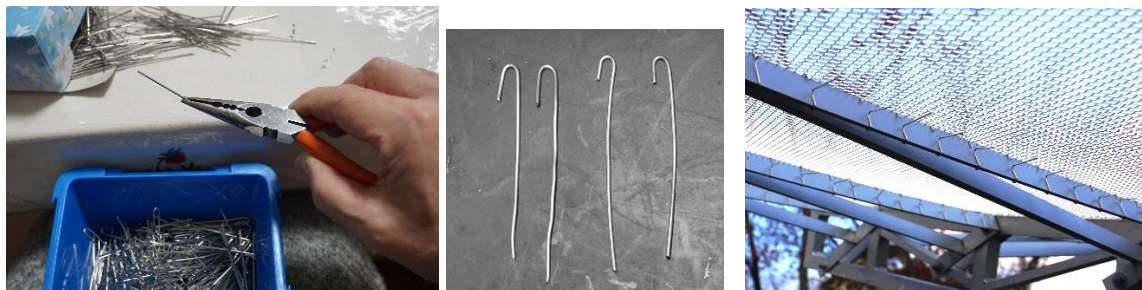

### Caution!

**Stainless steel wire will fly** when you cut it. Put some 70-80 mm of it into a hole of a closed box, and cut just at the outside of the box. You can keep the cut material in it until you bend it.

### Removal of Rust and Repair of Hub

Dish hub, made of a spool and a ring, are made of steel. They were badly corroded, and rust was so thick. Metal brush did not work well. So that **air-powered chisel** was used for very fine job.





Rust was removed using air-powered chisel.



Thickness is measured at several directions.



Dimples were filled with epoxy bond, E250 A&B, mixed up, smeared, and smoothed after dried up. The thickness was finally adjusted by a file. Since the epoxy bond do not come to metal-hard (but still enough hard for this purpose), this pate may be better for metal materials.

GENUS GM-8300, 250 g/¥9k. But this metal-hard material should be very hard to file!

After the dimple repair, metal materials were painted with anti-corrosion gray pain, and then in favorite color paint.



## ANTENNA PLAZA

The hub ring and spool, and trusses were transformed to ANTENNA PLAZA, where I named for this “new TVRO” to be built. Hundreds of trees and bush here were cut down, the roots were dug out, flattened and paved with cobbles and asphalt. Antenna construction began in May, 2021.

Here is good neighborhood. It was a rice pad this year. Another side was a hey yard now, but sometimes rice pad, or potato or green peas. You can see my 4.4-m TVRO over here.



4-m section was attached to the hub spool, and to hub ring with an aluminum block and tapered washers. The procedure of this antenna construction is almost SOLO operation! So, it took time!

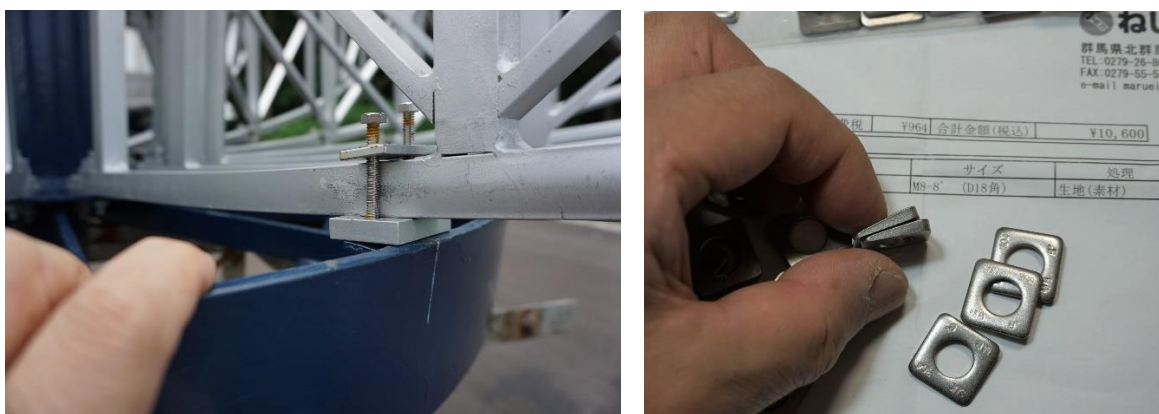

After 16 trusses of 4-m section were attached to the hub, **the level and the diameters of the section were inspected using yellow strings and a tape measure.**

Be careful, some **tape measure made in China** is terrible. The scales are clearly printed, but the **accuracy is hell!**

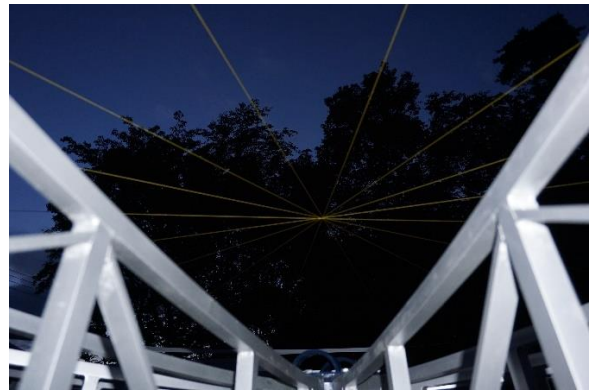

The level of each truss was perfect, and antenna diameter was within 1 mm difference at every end to end. The center matched. Then the outer mesh rings were attached at the end of trusses.



The last one outer mesh ring was too tight, and difficult to insert before the dark!

### 6-m section

Every truss of each section is connected by a couple of **M8** bolts (instead of  $5/16''=7.9$  mm), aluminum blocks, flat and spring washers and nuts. Connecting bolt and nut should be tightened enough, and truss pillar is protected by strong stainless square washers and aluminum blocks, and would not be depressed at all.

**To 4-m and 6-m truss sections, 7 types of mesh rings were attached.** (About the shapes of the mesh rings, see the mesh ring design of the extended section, above.) L-angle strait bar behind the ring for enforcement, and flat bars at the end of each ring to bolt, and also to enforce the truss connection. **Two 1/4'' bolts** were used each side for all of the mesh ring connection.

These bolts should not collide nor cross other bolts inside the truss pillar.



Monkey spanners, strong graspers, and MAKITA impact drill/screw driver are necessary for SOLO operation of mine. Finally, the bolt/nut should better be tightened by hand for the proper force. Or 1/4" steel bolt would break easily, and if you use stainless bolts, they will stick easily.



Early 2021, 6-m truss section was started.



31 July 2021, all mesh rings of 6-m finished.

By the end of July 2021, the truss and ring construction of 6-m section was finished. For the **pedestal tower modification** (used 6-meter tower from my old Tri-Ex Sky-needle, a special version) and rotator design needed more time at a local factory in concern. And I needed time for mesh cutting, and the design of the extended section, motor controller, AZ/EL encoder box, etc.

### Cutting Out of the Mesh Reflectors

Since all of the original mesh sheets had been lost, I had to design every part of the reflector mesh from the new material. **Aluminum expanded mesh sheet (branded as Art Mesh) of 1000x2000 mm** became the candidate. From the catalog of **Suzuki Technos Co.**, Tokyo, my choice was of **7x14 mm mesh, 0.8 mm thick, weight 1.24 kg@**.

First, I tried to calculate the mesh dimensions and cut out from a sheet so that less amount of the material could be left. But the exact calculation seemed to be complicated, so I decided to **trace each mesh size directly from the real antenna structure** onto a mesh sheet directly, or to a thick vinyl sheet with 50 mm square grids printed on the surface (photo below), and a felt sheet glued on the other side. This material is originally used for the protective purpose of house construction.

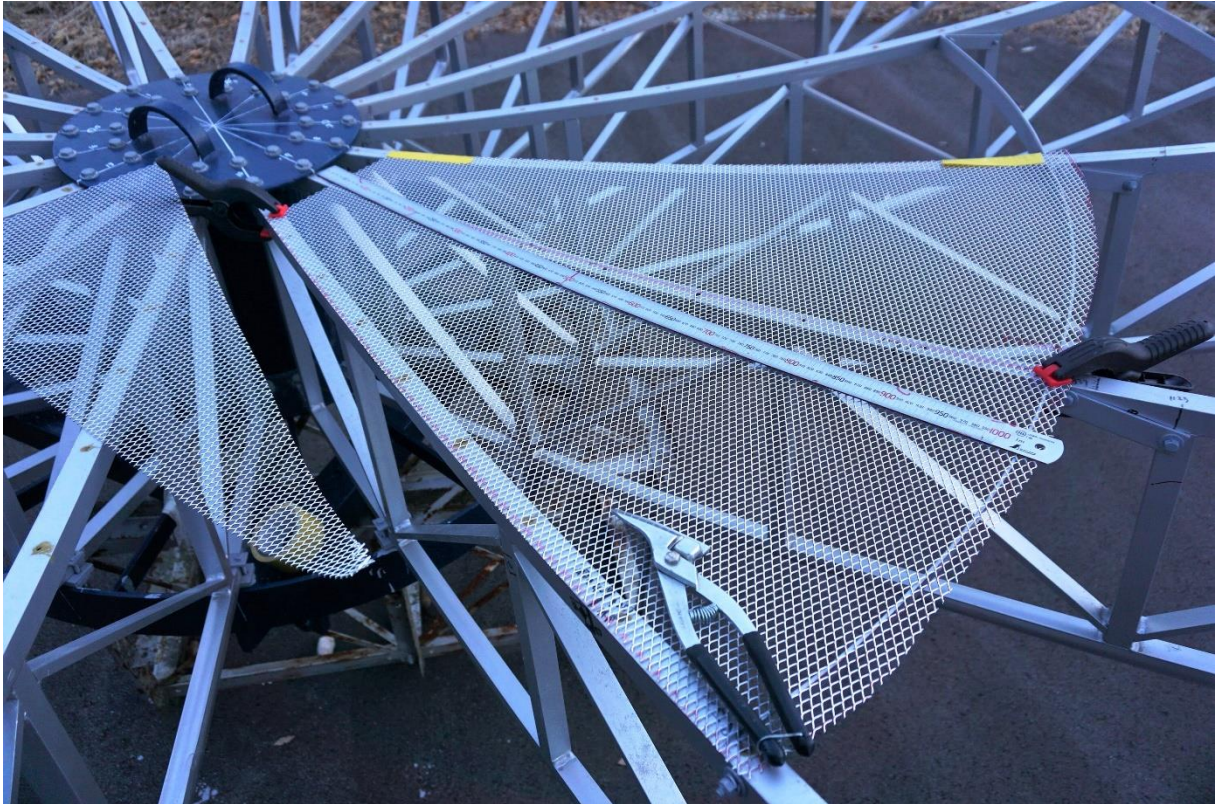

This method revealed (as was estimated) that **every mesh sheet spread on the trusses and mesh rings could be almost trapezoid, and only a few centimeters swelling slightly to the both sides.** This tendency becomes more remarkable in the outer mesh.

Cutting was done on the floor or on a wide table (maybe better) with a metal scissors or a hand cutter called *guillotine*. **Four types of reflector mesh sheets, 16 pcs. each, 64 in total** were cut out.



I first estimated 40 new mesh sheets would be enough for each set of reflectors, but caused by my mistake, 5 sheets had to be made from the cut material by connecting with rivets. It took some 30 minutes each, but the material loss could become less. Rivet connection seems to be strong enough.

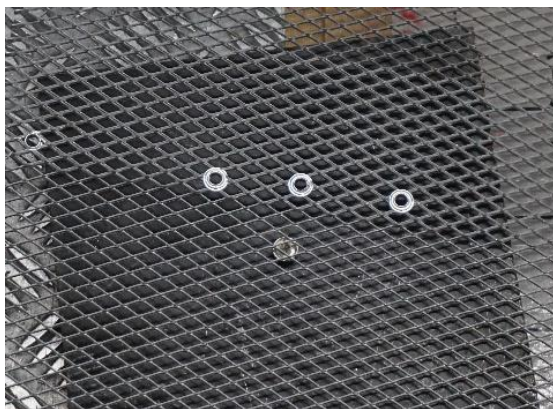

Rivet is a better choice, even if it takes some time. (photo above)

You can “weave” the mesh sheets by themselves. But it takes more time! (Below)

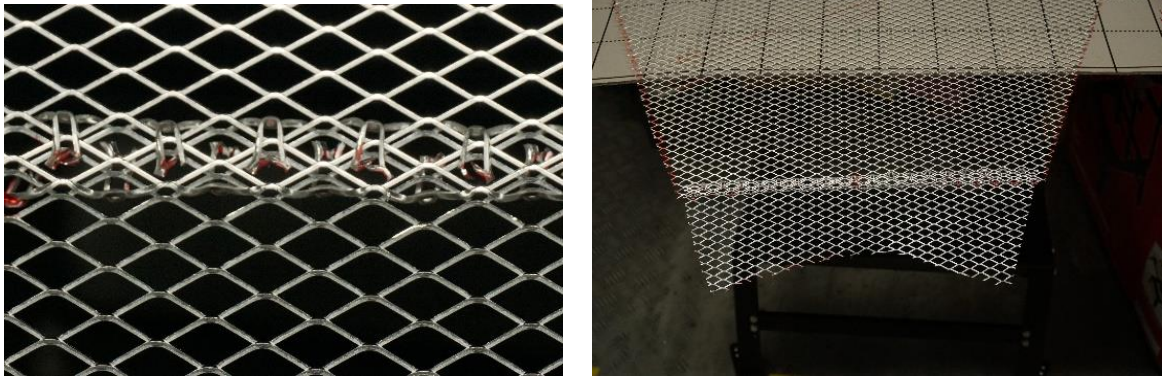

Note: **An expanded metal sheet has its surfaces, front or rear, and direction, up or down. When you overlap two mesh sheets, it makes difference.** To stack the two mesh sheets smooth and stable, keep the rule above for better overlapping. Each mesh sheet would **slip, or stick**, one another by themselves according to the rule.

Cut edge of the mesh will **prick** you. You need to wear skin gloves but it will be penetrated easily. So please be careful to treat the metal expanded mesh!!

A friend of mine, Kazuo Sudo, JH1OHG, a retired carpenter, told me these fundamental rules.



front



rear

### Dish Tumbled

December of 2021, it was after about 30 % of the reflector mesh were attached to the 6-m sections. A windy night broke, and I found my dish had turned off from the pedestal. One truss section got severe damage, laceration, and needed repair work.

Dish had been tied to the pedestal by steel wires. The pedestal itself seemed to have turned 90 degrees, and steel wires were cut off when the dish dropped off and hit the asphalt ground.

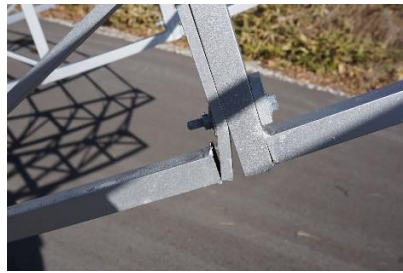

Several damages were found. This section was removed, and went to a local factory for repair.

My friend a retired carpenter, soon called a crane truck at lunch time. Good friends are always helpful. TNX again to JH1OHG and his friend, too! Dish was settled down on bricks to keep its lower profile. This posture was better for preventing wind load, and for easy work that follows later.



One day the weather forecast said a **very strong typhoon** was coming. I prepared for it in the rain. Dish hub was firmly tied to 4-m or 5.5-m of 50 mm dia. steel pipes on the ground. Former pedestal was used as an anchor weight and a side support (photo right). No damage this time.





### Mesh Attachment and Expansion to 7.8-M

Since the manufacturing the antenna tower pedestal and motor section had been delayed at my local factory, I did not proceed the mesh attachment. In this area we seldom have typhoon damage in summer season. But in winter strong winds blow well-above 15 meters/sec. and we sometimes have stormy days of over 20 cm of snow fall.

Instead, dish trusses up to **7.8-m truss section** including three types of mesh rings were continued to built up slowly along with mesh reflectors cut-out. From time to time the dish diameters and accuracy of the center were proved using **yellow strings**, scaling, and naked eyes.



Connection of the extended truss was tried to adjust the curve with washers, but no need!

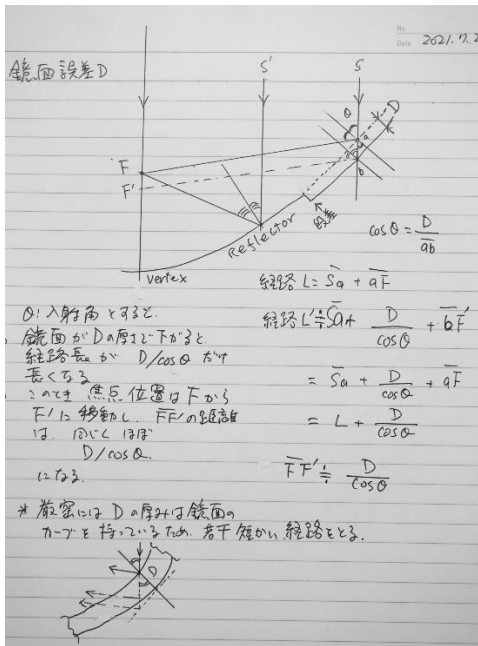

If the dish surface comes to a different position (D), this surface gives another focal point. The difference from the original focus (F-F') would be  $D/\cos \theta$ .

$$F-F' = D/\cos \theta, \quad \theta : \text{angle of incidence}$$

If the reflector surface of the same curve inclines inward or outward, direction of the dish front would also incline to the same direction. Then feedhorn in the original focus would lose its phase center in good position, and less illumination to this reflector occurs by phase error and defocusing. (Please ask the details to Paul, W1GHZ. TNX!)

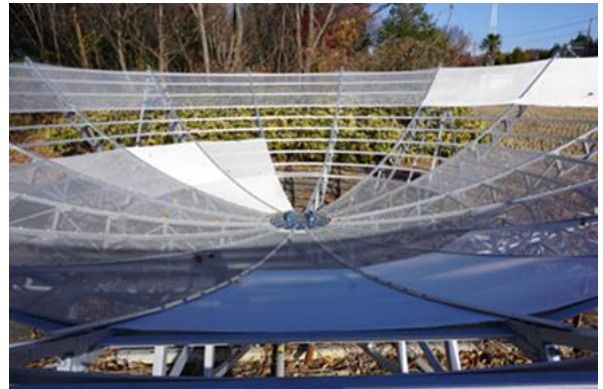

The last mesh ring, the 160th ring, was bolted November of 2022. To design these mesh rings for the mesh D, the most outer part, manual calculation with CASIO was, as usual, precise and perfect,

but I sometimes made mistakes in formula, or typing. The last rings had to be remodeled for the proper dimensions. All the mesh trimming was finished and attached to the dish surface.

By the way **this TVRO is strong and safe enough to walk on the trusses (at least for me, 75 kg)** for drilling screws, painting, or adding mesh clips. See **the video** in my slide show!

You might walk like a cat on the reflector, but a cat cannot go back and perhaps jump out.

### Paint in Matte Black

It was a lonely process to trim the mesh sheets, and attach onto the dish trusses. Along with this process, I asked several people who are keen in antenna construction what paint I shall use.

Someone answered matte white, others silver. **Michael Kohla SA6BUN (also DL1YMK) replied MATTE BLACK is the best.** My former antenna is colored in dark ultramarine blue (almost black), and it does not keep eyes of others who are not interested in amateur radio/antennas. In this area there is no restriction in color or size of our construction except for the height of permanent construction. But the area is close to world-famous **Nikko National Park**, many people come for sightseeing. **Better be stealth!**

Painting began from the central position, “mesh A”, first. Then “mesh B”. The most outer “mesh D” proceeded before the “mesh C”, for easier construction and painting on a ladder-steps of 2 meters high.

After **primer paint** was done, front and rear surfaces of the dish were totally **painted two times in matte black**. During this process, some inches of snow fall was experienced. It proved the snow melted rapidly on the painted surface.





Six 2-L cans of matte black acryl paint were consumed. Paint roller for flat parts, a brush for other.

### Access window

To finish the mesh attachment and paint, a few mesh sheets in the central part had to be open. In order to come in and out from the surface of the dish, a door was made from flat bars and mesh sheet. It is easy to open or close from behind the dish. Locking mechanism is not yet made. A rubber strip or something?

There are two other reasons I need of this window:

- 1) To lift this dish by crane at the center. Someone has to release the bundle.
- 2) Feed stay-arms have to be settled upward when the dish is lifted. After the dish is installed on the tower, feed stay-arms would be settled down to the center for the dish installation.

Since the feed-horn is far up from the dish surface, I dare not approach to it from here. Do you?

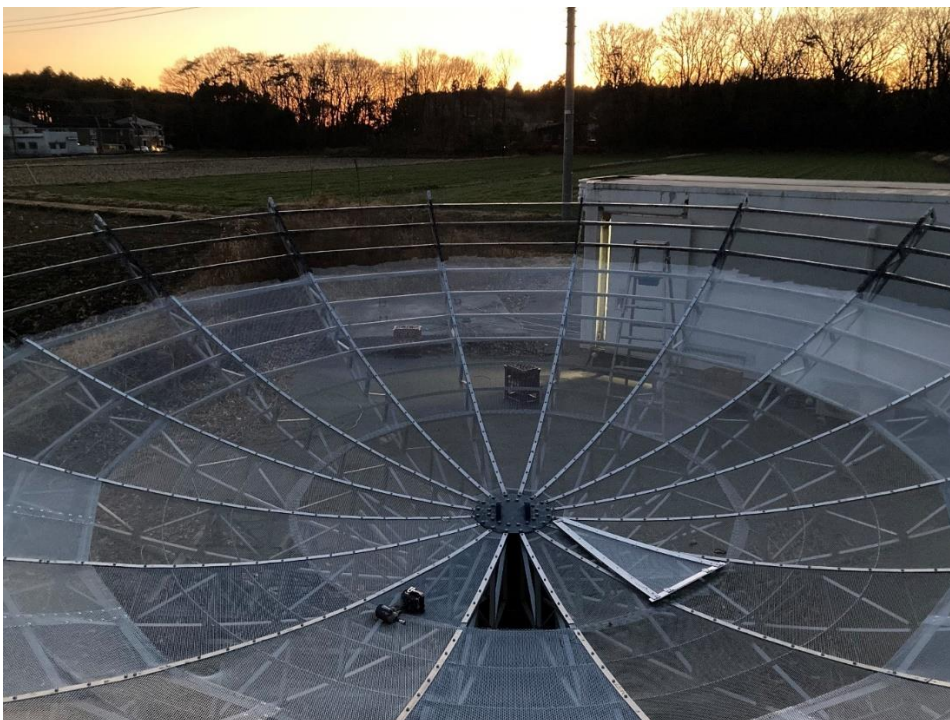

## Modified OE5JFL/HB9DRI controller

Hannes, OE5JFL, is a well-know EME operator, a teacher, and a skilled pro engineer. He issued an excellent stand-alone antenna controller for EME, which tracks the moon, the sun, and other celestial bodies, without using external computer. Alex, HB9DRI, ZS6EME also, reproduced the controller boards with LCD display. Hundreds of EME operators use this system.

Walter, ON4BCB, followed and issued DIY controller, and later showed a modification of the L6203 H-bridge replaced by **IBT-2 (BTS7960 chips)** H-bridge for larger DC motors, up to 27 volts 43 amps. In this **modification directly from DRI board**, the **input of IBT-2**(=output of control board at manual switches) has to be biased **5 volts through 10 k ohms**, otherwise it would not work again once you push manual button of any direction. (Driving voltage never comes up from low.)

Another problem with IBT-2 is **birdies of each 22 kHz when AUTO mode begins** to rotate the antenna. It continues several seconds until the original PWM mode finish. Bypass capacitors and ferrite choke beads, and metallic cabinet would reduce the beat to your receiver.

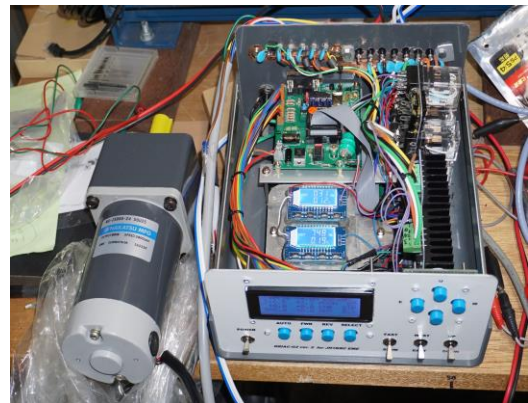

IBT-2 H-bridge



PWM oscillator

**Pulse Width Modulator (PWM) oscillator** of a Chinese product was installed for **slow manual control**. OUTPUT: +5 volts, switchable Frequency (Hz) and Duty (%).

The reason why I needed to use manual PWM control was that the motor I use for elevation control has too much speed. **5 to 10 times slower from the original motor speed is preferred**. I thought

PWM motor control must help for this purpose. But...problem happened.

### AZ/EL motor control

**Azimuth rotator** is almost the same as I use for 4.4-m TVRO; 90 watts 24 volts DC geared motor and a precision worm gear, and 5:1 chain drive. It takes approximately 4 minutes to turn 180 degrees. **Drive chain is tightened by screws** on the motor holder plate to push it back. JA6CZD explains he used a car jack, put it between the mast and worm gear box to push it back, so that the chain would be tightened enough for microwave EME. Of course, worm gear should have less backlash. Chain driving of **5:1 reduces the backlash of worm gear to 1/5**, if the chain tension is tight enough.



For **elevation (take-off angle) control**, this power cylinder was selected.

**LPF-600L: 8 mm/sec. 6kN. 24 Volts DC, 10 Amps, Tsubaki, made in Japan.** 400 mm/50 seconds is **too fast** for manual operation. Upper and lower limit microswitches are externally installed. Switch handles only a few amperes, so need some relays for the DC control.



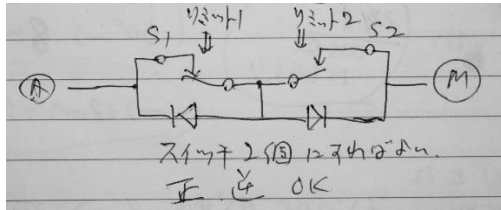

An example of UP/DOWN limit switches

### Azimuth Encoder

DRIAC-G2 included **absolute encoder MAB25**. Still, I have several pieces. Some has tight rotation, and other not so. I selected some smooth ones for AZ and EL detectors. To prevent water drops, an **umbrella** is prepared again. This is a useful method I have experienced for over 10 years. A **flexible shaft coupling** is also useful to protect this cheap encoder and promise smooth indication.

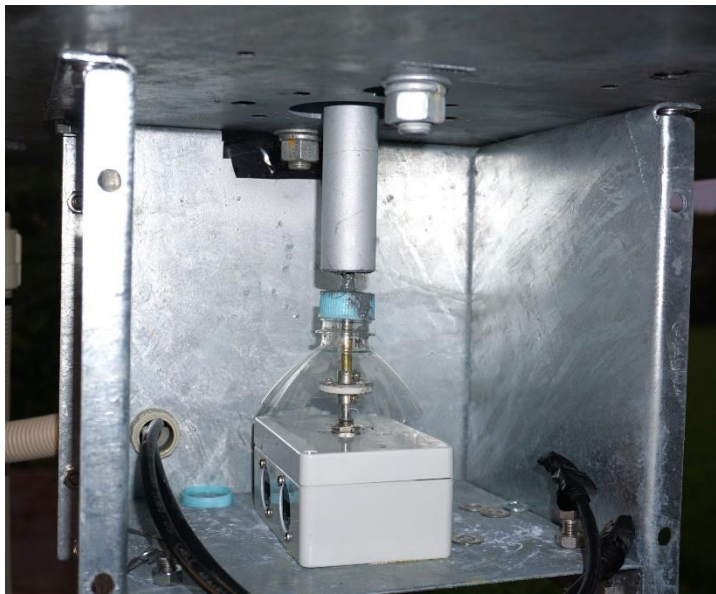

Two connectors for LAN

### Lift Up of the Dish

May 2, 2024, **6 meters dish pedestal tower** arrived and erected on the concrete base. After the tower was investigated by simple string method proved to be perpendicular, modified 7.8-M TVRO was installed on it.



**Four feed arms are vertically fixed previously**, so that a crane was able to lift up the dish at the center hook. Feed arms are able to move their positions by pulling ropes tied in “triangle configuration” before you install a feed horn.







Bearing shaft 60 mm, Axis is solid steel rod 75 mm. Vertical rotary mast is 90 mm dia. solid shaft.

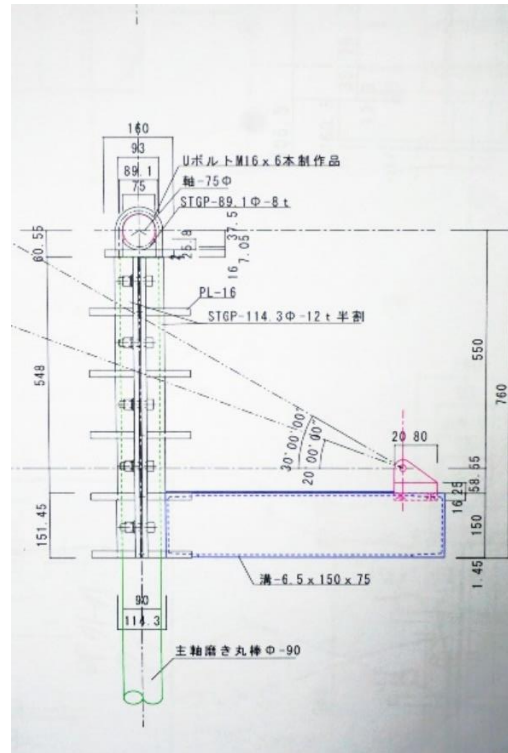
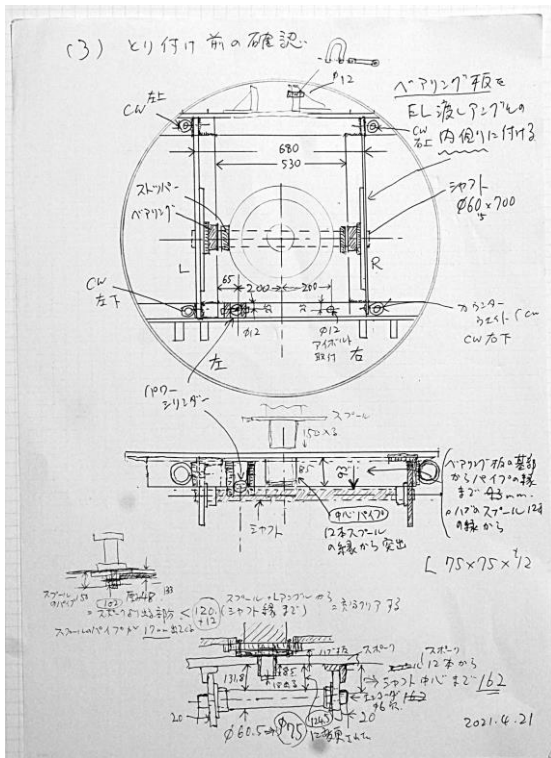

## Counter weights

Steel plates 16 kg@ would be added 6-8 pieces each on both sides of the counter weight arms. Since the exact balance weight is unknown, 100 kg antenna balance weight at 100 cm from the elevation axis was estimated. Calculation showed 4 kN of power is needed at -5 degrees of elevation, and it reduces to 2 kN around the zenith. In the first test at ZERO degree, 65 kg (weight of a man) needed to turn up the dish, and 4 pieces were added for the balance. It looked marginal. More 4 pieces are added, and it became almost OK. It seemed 8 pcs. on each side, total 260 kg would be fine.

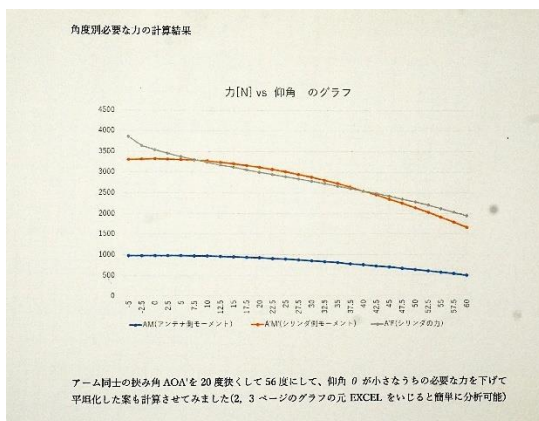

## PMW is not a magic

Motor test continued, up and down by PWM manual switches and chose any certain rate for the proper movement. Still, **it appeared very critical in antenna movement. A PWM rate selected for fine movement in upward elevation, it would not be proper for downward, and vice versa.** Sometimes the motor DC voltage had to reduce to control the high speed, and in other occasion too much DC current flew >20 amps. in unbalance conditions, or caused by inertial moment, or both.

## Be aware!

Since the **power cylinder I selected for elevation has too fast speed** for ordinary manual use, I thought PWM DC control would work fine. Just after my TVRO was installed, I experienced extraordinary affairs to make serious troubles. It was caused by **my misunderstanding about how DC geared motor works under a simple PWM control.** These cautions should be taken before designing the rotators, specially for a heavy antenna.

1) **PWM** controls the rotation speed of motor toward normal direction. But **PWM itself DOES NOT WORK** as an **ACCEL** (picture left) nor a **BRAKE**(picture right) in order to keep its speed constant.



AI drawings of COPILOT

2) **Motor speed**, operating in PWM mode, will increase if any wind pressure, or unbalance of weight, gives forward force.

3) **Inertial moment** will increase by unexpected external additional forces, such as wind pressure, or unbalance of weight, etc.

4) **PWM-controlled motor does not start rotating** until the PWM pulse duration and frequency give enough energy to motor for the initial moment of rotation, even if the motor specification and voltage are satisfactory.

5) For the proper and safety motor control with PWM, **the PMW rates have to be controlled by feedback** (automatic, or manual). This could be a conclusion of PWM control.

So, one of the results was this:



During the upward movement of my antenna, wind blew and drove the antenna upward. Motor load became lower in high elevation angle. Limit microswitch might have worked to put the power off, but the antenna moved upward a few degrees more than limited (estimation). The cylinder collided the elevation axis, a solid steel bar above, and bent.

After this trouble, my antenna construction temporarily stopped until the effective solution comes in.

### **Solution?**

In order to repair the elevation rotator, a **DC motor-powered linear actuator** (Power Cylinder, Tsubaki) may be difficult to find for requested slow speed, and the limited length in my antenna. If the moving speed of this cylinder could be modified, slow down to 1/10 or so, by changing the gear ratio, it would be fine. Its cost is unknown yet. (I am asking if they can.)

Other choice would be a **slew worm gear drive**. Most of the models designed for photovoltaic (PV) systems look appropriate choice for our EME antenna rotator. Already not a few amateurs use the slew gear drive for their antennas.

Detail analysis of the problem I encountered, and possible solution I may find would be reported later. So, my apology for my dear DINOSAUR not here today. He will be back soon, I hope!!

### **References for Slew Gear Drive**

For large-size dishes, SA6BUN (also DL1YMK) Michael and ON7UN Eddy showed fine presentations at Orebro. Essential properties of slewing gears and practical implementation for zero backlash dish support structure and some pictures would be in these slide shows (see web):

Michael SA6BUN(DL1YMK) gave a presentation about slewing gears at Orebro 2015  
Eddy ON7UN: Rebuilding a 6 m Dish antenna (slide show), Orebro May 20, 2017

### **Acknowledgement**

During these 20 years of my EME carrier, I visited many OM's to learn how they built and move their EME antennas successfully. It was my great pleasure to have chances to ask them many questions, took or given hundreds of photos, and hear what they think about. Unfortunately, in some other cases, I have not seen their fine antennas into details before they went silent key, or antennas dismantled. Only the stories remain.

In my personal opinion, these fine antennas must fully be described and recorded with photos, graphics, data if available, and show how these antennas work in real moon-bounce communication. Otherwise, I cannot learn more from them. Already I have learnt from some fine articles in radio magazines, or on the web. TNX!

Many thanks again to whom I used their photos in this presentation/slide show without their previous permission. Special thanks to Dr. Allen Katz K2UYH who allowed me to be here, but we cannot meet any more, our host College of New Jersey, Paul Andrews W2PHO, co-Chairman of the Trenton EME conference, and Paul Wade W1GHZ for the session and proceedings.